



# ON-A-ROLL® LIFTER POWER UNIVERSAL HI-RISE

**ELIMINATES  
MANUALLY LIFTING  
AND LOWERING  
ROLLS —**

**SAVING TIME  
AND KEEPING  
OPERATORS SAFE**



- This versatile lifter fits laminators and many other printers requiring 54" lift height.
- The power DC motor enables users to effortlessly lift rolls as heavy as 660 lbs (300kg) and as wide as 13 feet (400 cm)
- The flat roll loading tray fits most laminators and easily reaches the upper loading shaft height. Two adjustable roll wedges position rolls on the tray and can be easily removed for loading and unloading.

## Outstanding Features of the 61565 Power Universal Hi-Rise



The tray lifts and lowers with the push of a button, using standard outlets for recharging.



3"H front swivel casters fit under laminators and other machines with low clearances.

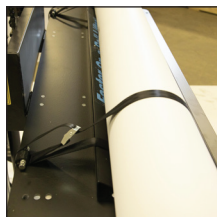

Safety straps secure rolls to the tray and prevent shifting during transport.



54" lift height reaches top roller.

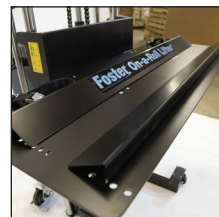

Removable roll wedges and flat roll tray fits between rollers and openings.



Model 63161 optional Roller Platform is designed to allow operators to feed rolls into their machines directly from the lifter.

*See drawings and dimensions on page 2 to determine if the 61565 is right for you*

800.523.4855 or 267.413.6220

PO Box 389, Lafayette Hill, PA 19444 • customerservice@go-foster.com • www.go-foster.com



# ON-A-ROLL<sup>®</sup> LIFTER POWER UNIVERSAL HI-RISE

## SPECIFICATIONS 61565

Roll Weight Capacity	660 lbs (300 kg)
Lift Height	54" H (135 cm)
Max. Roll Width	13' (400 cm)
Max. Roll Diameter	15.75" (40 cm)
Overall Media Lifter Dimensions (W x D x H)	47.25" W x 35.5" D x 68" H (120 x 90.3 x 173cm)
Media Lifter Weight	271 lbs (123 kg)
Bottom Fork Clearance	3.25" (8.25 cm)
Front Swivel Castors	2" (5 cm)
Rear Swivel Castors	5" (12.7 cm)
Electric	12V/60AH DC motor USA (220V/50HX DC motor Europe)
Battery	Maintenance-free lead acid battery
Charger	Built-in 110V AC charger USA (Built-in 220V AC charger Europe)

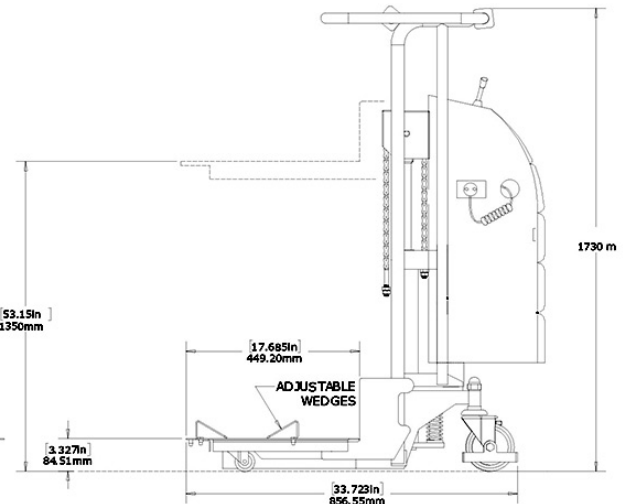
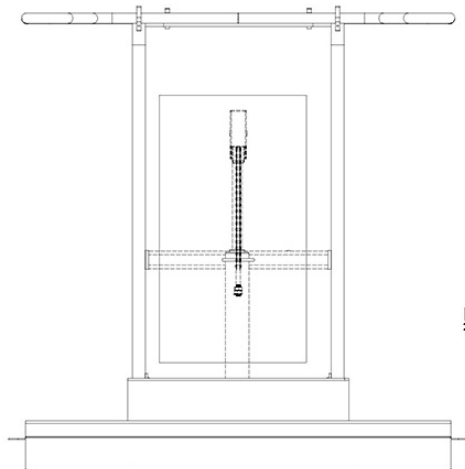
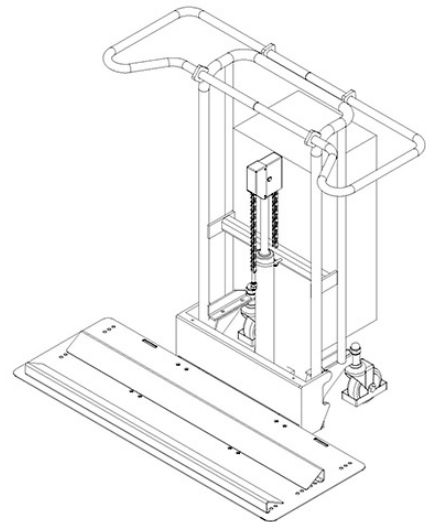
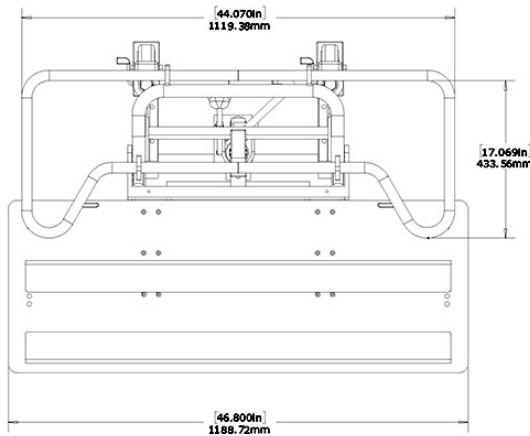

**2-YEAR WARRANTY** on hydraulics and media tray  
**5-YEAR WARRANTY** on cross bars

**800-523-4855 or 267-413-6220**  
**Customerservice@go-foster.com**  
**www.go-foster.com**