

# Height Adjustable All-A-Board Lifter®

# Foster

ONE OPERATOR can safely handle any job.  
Effortlessly load and move heavy rigid substrates through your facility.

**“I don’t know how Color Reflections could manage without this Lifter!”**



“We have machines of many heights in a bustling shop. Thanks to this new Lifter, we can stage several jobs simultaneously on mobile work benches. We are always on a deadline. Foster’s Height Adjustable All-A-Board Lifter® moves heavy, rigid substrates along so quickly that we can meet our deadlines. To produce the best graphics, Color Reflections has three vital needs: Reduce injury, expedite production, and make things easier for our employees. **THIS LIFTER DOES ALL THREE.** We have several, and our staff is thrilled.”

Eric Berger, Owner  
Color Reflections  
*A leading provider of digital color printing and graphics*

*Reduce injury when transporting materials thanks to the Lifter’s ergonomic design.*

*Jobs remain in mint condition thanks to the hydraulic foot pump that adjusts in height from 34” to 42” to fit most printers and finishing equipment.*

Scan this code for  
more information



Foster – since 1948, evolving to meet the needs of your printing and graphics company.



## Height Adjustable All-A-Board Lifter®

Reduce injury, expedite production, and make things easier for your team. Ergonomics is an investment that benefits your people and your bottom line.



*Operators can quickly and safely feed boards onto printers, cutters, and laminators without bending or lifting.*

*ONE OPERATOR can safely handle any job. Effortlessly load and move heavy rigid substrates through your facility.*



*In a flat position, the Lifter functions as a mobile workbench that quickly moves from station to station. This frees up valuable floor space while operators can work on multiple jobs requiring different steps for finishing.*



*One operator can move 500 lbs. of rigid substrates from warehouse to printing to finishing with minimal effort. Shops have so much equipment in a limited amount of floor space. These tables revert to a 3-ft-wide space.*



*Deck rails keep 8" stacks of rigid substrates from shifting and moving during transport and loading.*



*The tilt down and locking feature lets the operator safely move heavy rolls from horizontal to vertical position.*



*Save time with Foster's new Lifter that easily slides through doorways—no more carrying jobs to a workbench or printer.*



*Latch releases and locks on top of work surface.*



*Handlebar under the table for easy maneuvering of materials and rotating from vertical to a flat position.*

For more information and to see a video of this exciting lifter, please visit [go-foster.com/AllABoard](http://go-foster.com/AllABoard) or scan this code with your phone.



LEARN MORE

Contact Foster today at 800-523-4855 or [customerservice@go-foster.com](mailto:customerservice@go-foster.com)



# Height Adjustable All-A-Board Lifter<sup>®</sup> is like having an extra operator!

Model #61613 and #61612 specifications

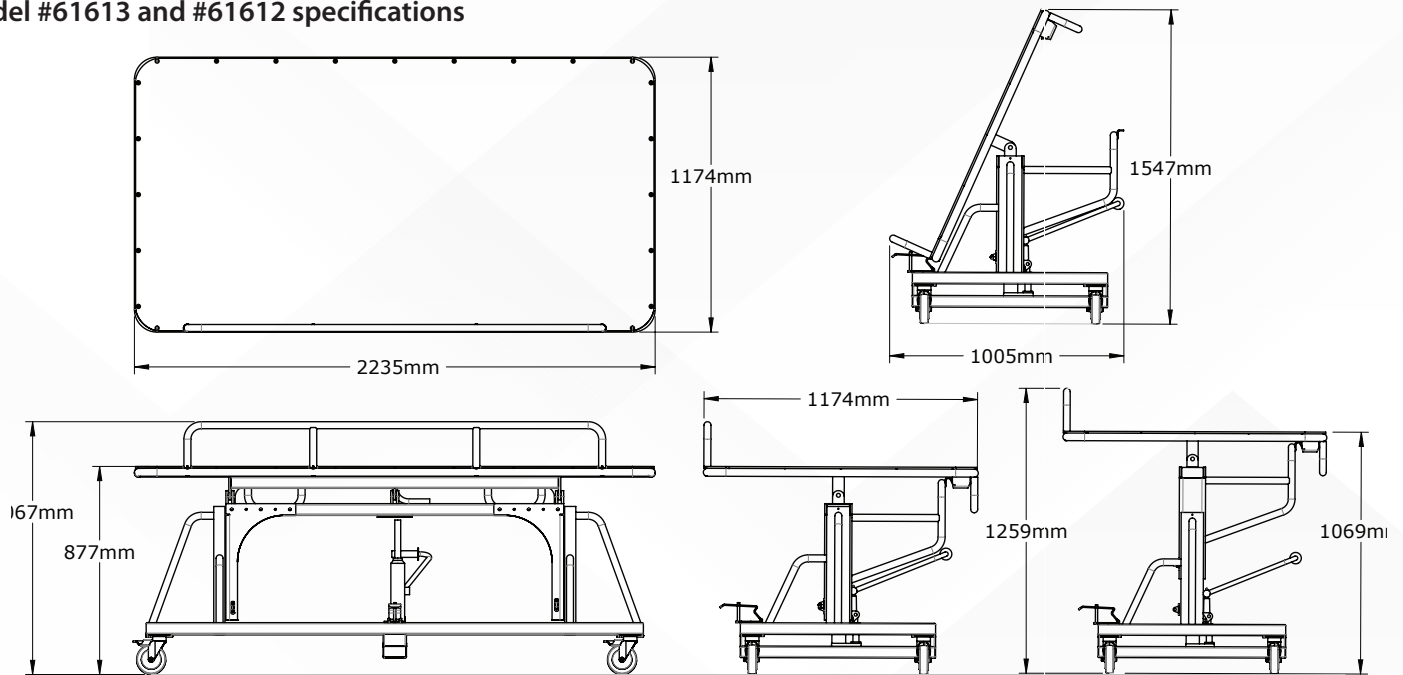

Model #61613 with fold-down rail for handling 5' x 10' sheets

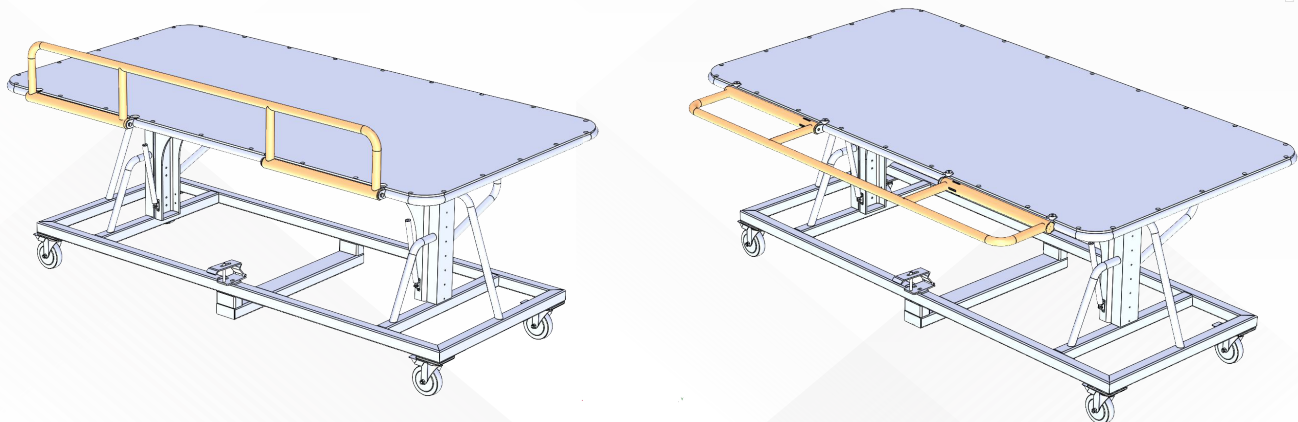

**2-year warranty on hydraulics. | 5-year warranty on the frame.**

## Features and Benefits

- Maximum Board Size: Model 61613 – 5' x 10'
- Maximum Board Size: Model 61612 – 4' x 8'
- Maximum weight capacity 500 lbs.
- Min/Max Deck height 34" - 42" H
- Max. tilting angle 66°(at 32" H)
- 3-ft. wide tilt in the vertical position guides the user through narrow aisles, doorways, & tight corners
- Functions as a workbench or table in a lat position
- Durable -deck surface fastened to Lifter frame with counter-sunk ( lat head cap screw) hardware prevents scratching and is impact resistant
- Four heavy-duty 5" diameter swivel locking casters for smooth maneuvering
- Welded steel frame ensures long-lasting use

**go-foster.com | 800-523-4855 | P.O. Box 389, Lafayette Hill, PA 19444**