

Foster

On-A-Roll Lifter®

Service Guide for Standard Models

This guide provides information on some common problems that may occur and steps to resolve them.

It is the user's responsibility to exercise good judgment, common sense, safety measures and reasonable limits regarding the use of the On-A-Roll Lifter® so as not to incur risk to the user or damage to the materials being carried. In order to obtain maximum benefit from your machine, please read these instructions carefully before using the On-A-Roll Lifter®.

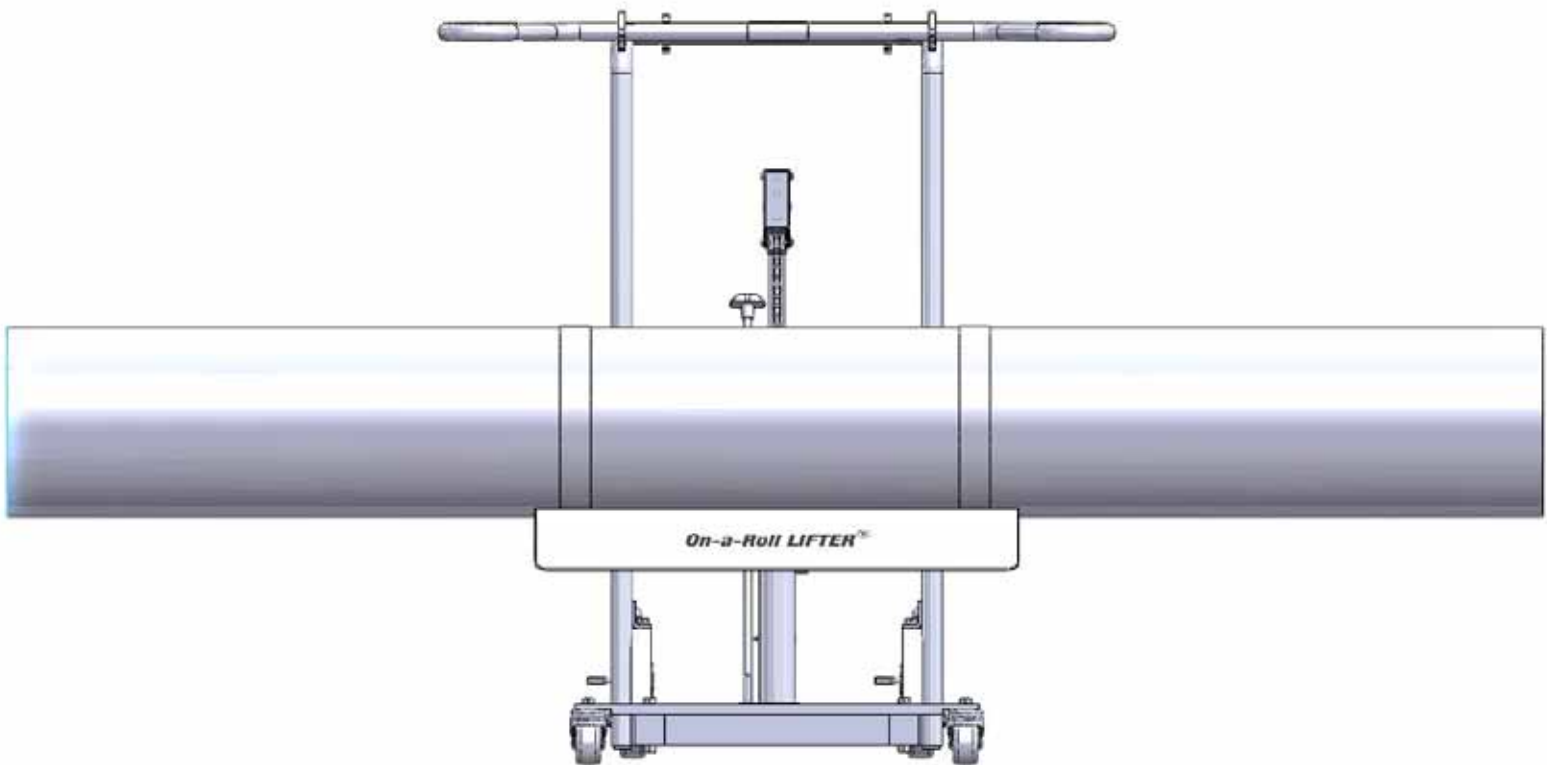

Contents

- 1. Parts Diagram**
 - 1.1 Complete Parts Diagram**
 - 1.2 Chain & Media Lifter Assembly**
 - 1.3 Hydraulic & Push Bar Assembly**
- 2. On-A-Roll Lifter® Wheels Not Turning Properly**
- 3. Oil Leaking**
- 4. Roll Not Lifting**
- 5. Tray Sinks Down Slowly**
- 6. Oil Leaking At Release Valve**
- 7. Oil Leaking At Other Points**
- 8. Inspecting Hydraulic Cylinder for Leaks**
- 9. On-A-Roll Lifter® Lift Pump Repair**

Parts Diagram

1 Parts diagram and list of components

1.1 Contact Foster before replacing any components or performing any adjustments that aren't currently mentioned in this instruction manual.

Item #	Description	Item #	Description	Item #	Description
63001	Support frame	63038	Pump lift/lower rod & knob	63076	Pump- foot pump pin
63002	"U" bolt nut	63040	Pump chain cotter pin	63077	Pump- foot pump roller
63003	"U" bolt washer	63041	Pump chain bolt	63078	Pump- foot pump tube
63004	"U" bolt	63042	Hydraulic pump chain	63079	Pump- foot pump washer
63005	17 x 3mm Support hex bolt	63043	Pump front chain guard	63080	Pump- foot pump top bracket
63006	Support/caster frame nut	63044	Pump chain wheel connector	63081	Hydraulic foot pump
63007	Lifter frame guide block	63045	Pump chain wheel	63082	Hydraulic foot pump cover
63008	Axel & bearing wheel bolt	63046	Pump chain wheel tube	63083	Hydraulic pump pin
63009	Axel & bearing washer	63047	Pump chain wheel lock	63086	M6 x 19mm bolt
63010	Axel & bearing wheel	63048	Pump rear chain guard	63087	Allen key bolt nut
63011	Axel & bearing thick washer	63050	Pump chain guard screw	63088	Allen key bolt washer
63012	Axel & bearing connector	63051	Pump chain support rod	63090	Media tray strap clamp
63013	Lifter frame	63052	Pump washer 1	63091	Media tray strap bolt
63014	16' Media tray	63053	Pump washer 2	63092	Media tray strap nut
63016	Caster frame washer	63054	Pump washer 3	63095	Push Bar Assembly
63017	Caster frame nut	63055	Pump top support	63096	8' Media tray
63018	Standard Front caster wheel	63056	Pump top support tube	63100	Hydraulic Pump Assembly
63019	Support strap for media tray	63057	Pump middle support	63105	Seal Kit for HP Assembly
63020	Caster frame	63058	Pump support washer 1	63110	Chain Assembly
63021	Rear caster wheel nut	63059	Pump support washer 2	63108	Pressure Release Assembly
63022	Rear caster wheel washer	63060	Pump spring	63120	16' Media Tray Assembly
63023	Rear caster wheel	63061	Pump top support	63125	8' Media Tray Assembly
63024	Pump screw (right)	63062	Pump pin	63140	Guide Bearing Assembly
63025	Pump seal (right)	63063	Pump connector	63155	Hardware Assembly
63026	Pump coned spring (right)	63064	Pump rubber ring	63186	M6 x 19mm bolt
63027	Pump steel ball (right)	63065	HP Small support block	63194	Split Washer for Standard Caster Wheel
63028	Pump screw (left)	63066	Hydraulic pump	63195	Caster frame Phillips head bolt
63029	Pump seal (left)	63067	Hydraulic pump base	63196	Support frame washers
63030	Pump rubber screw (left)	63068	Pump washer 1	63197	Standard Caster wheel bolt
63031	Pump coned spring (left)	63069	Pump washer 2	63198	Caster wheel plastic washer
63032	Pump pin (left)	63070	Pump washer 3	63199	Caster wheel metal insert
63033	Pump support	63071	HP Large support block	63200	Standard Caster wheel support bracket
63034	Pump lift/lower support	63072	Pump foot pump bolt	63201	Standard Caster wheel Assy
63035	Pump lift/lower spring	63073	Pump foot pump bolt 2	63203	Push Bar Rubber Sleeves
63036	Pump lift/lower tension bolt & nut	63074	Pump- foot pump bracket		
63037	Pump lift/lower tension connector	63075	Pump- foot pump nut		

Parts Diagram

1 Parts diagram and list of components

1.1 Contact Foster before replacing any components or performing any adjustments that aren't currently mentioned in this instruction manual.

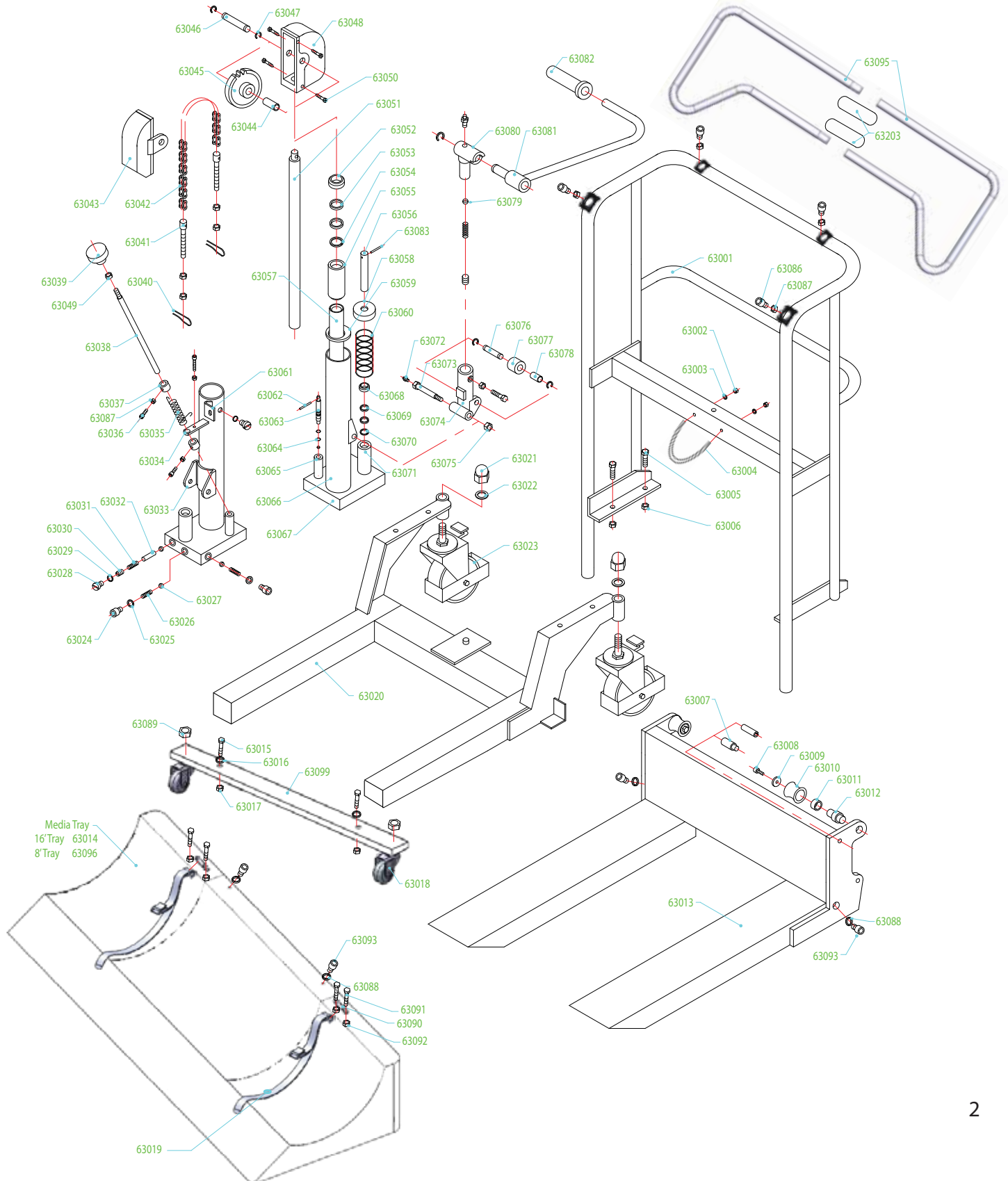

Parts Diagram

1.2 Parts diagram: Chain & Media Tray Assembly

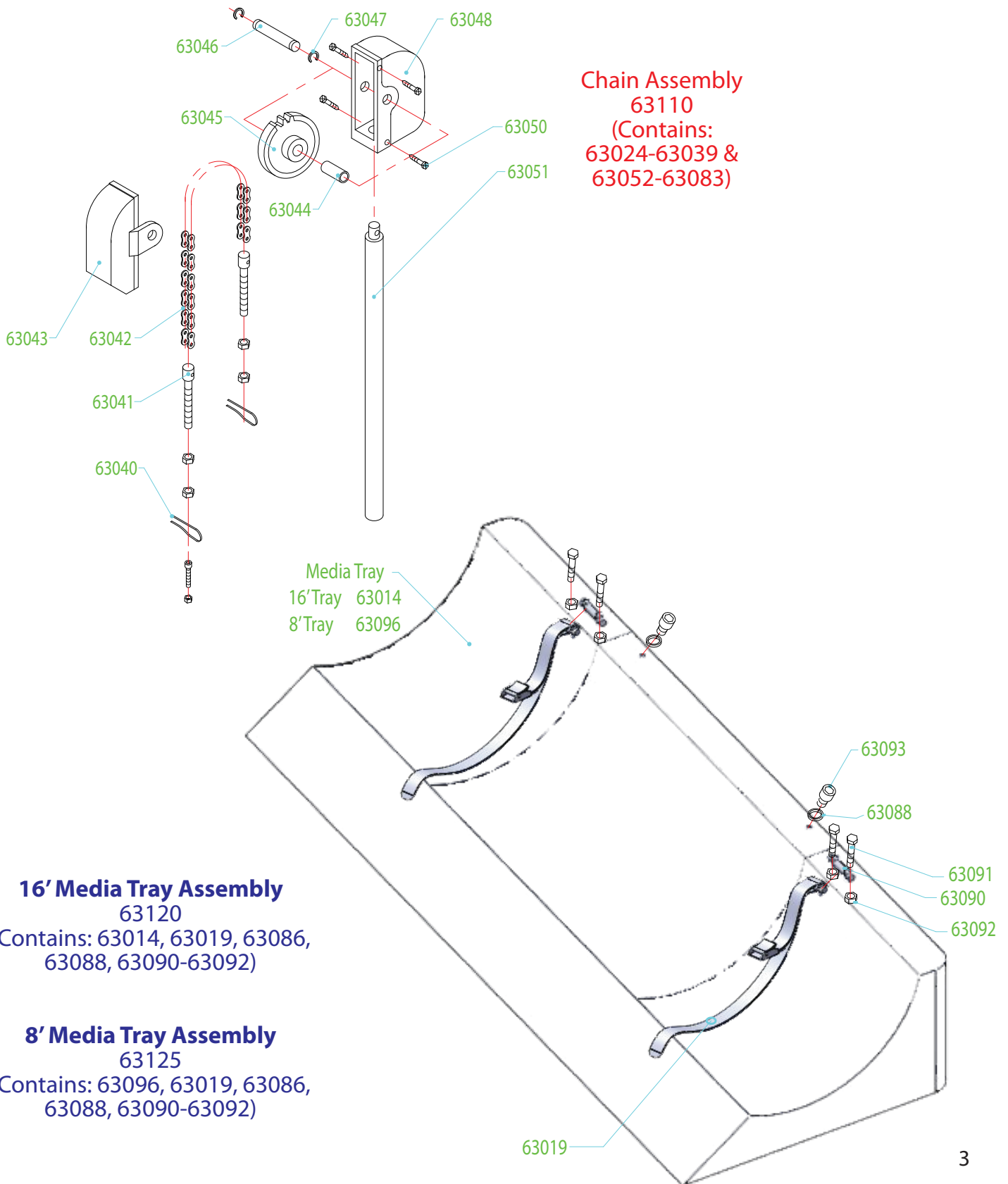

Parts Diagram

1.3 Parts diagram: Hydraulic & Handle Bar Assembly

Complete Hydraulic Assembly
63100
(Contains: 63024-63039 &
63052-63083)

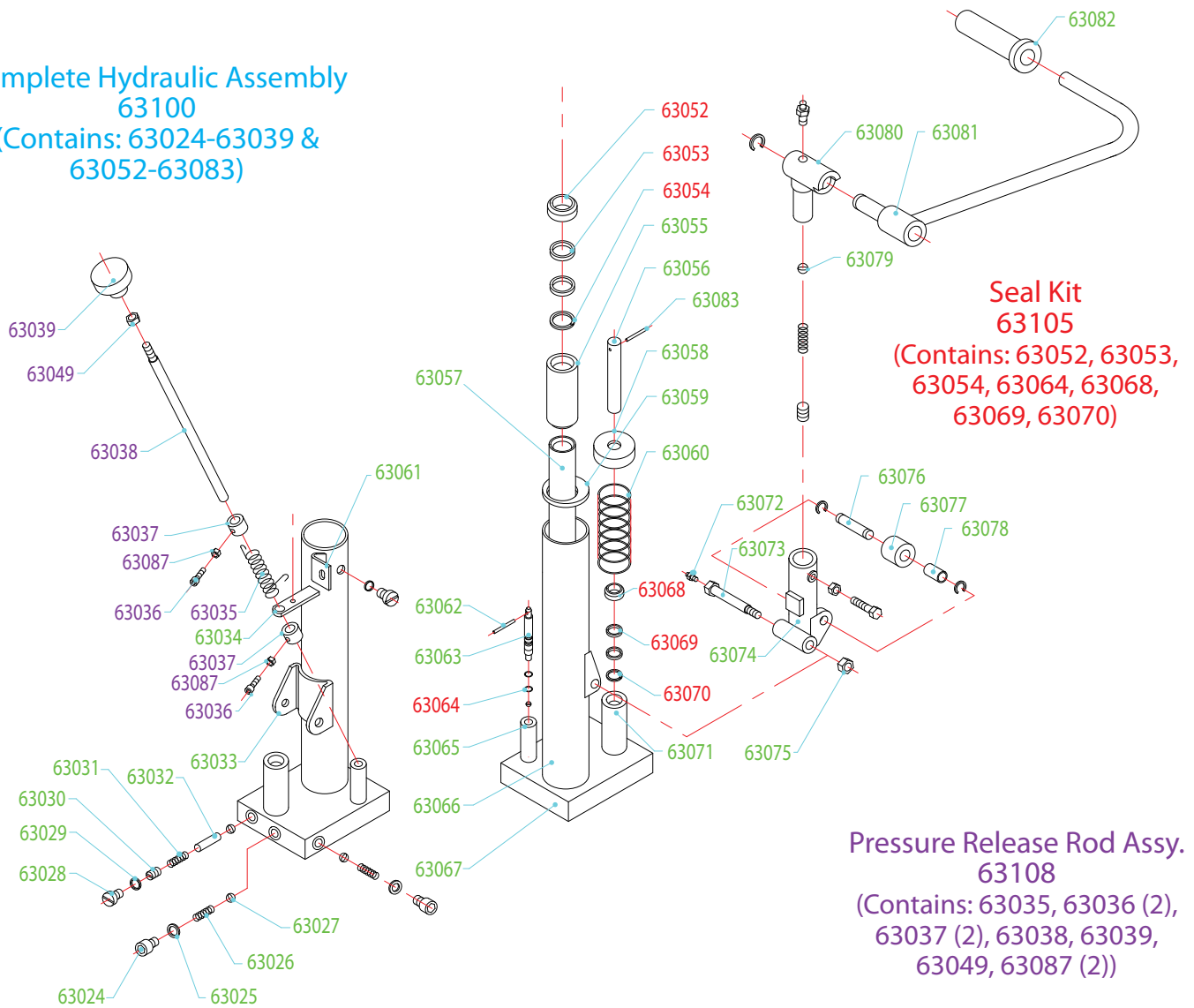

Push Bar Assembly
63095

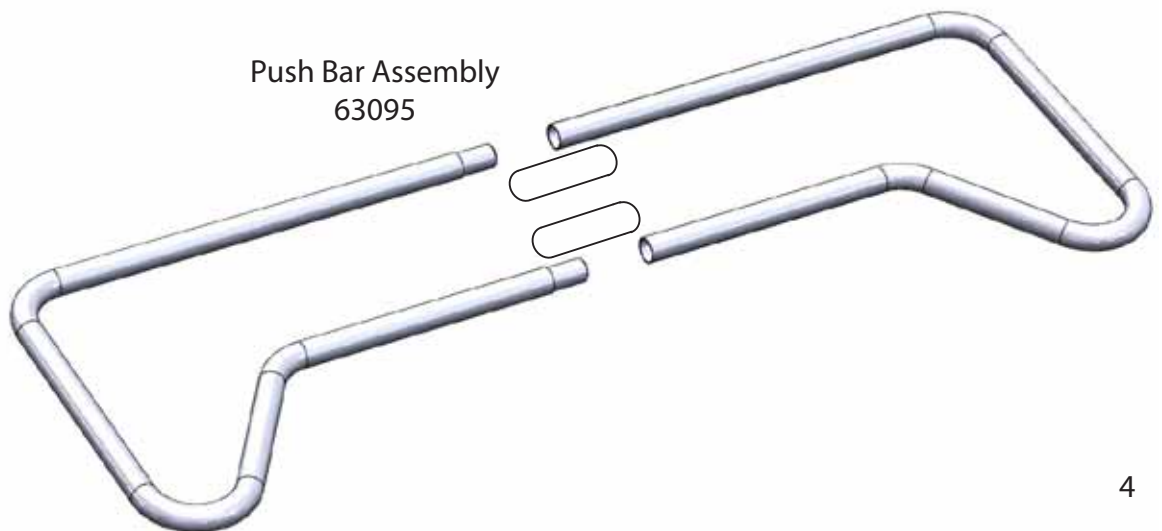

2. On-A-Roll Lifter® Wheels Not Turning Properly

1. Lift the front side to ensure the front wheels are intact and turning. Replace if damaged.
2. Lift the back side to ensure the steering wheels are intact and turning. Replace if damaged.
3. Ensure the cross bar is straight and not bowed. If the cross bar is bowed, the likely cause is that the user has dropped the roll media onto the tray or the roll weight is in excess of the recommended weight. Replace if damaged.

3. Oil Leaking

1. Remove the 2 nuts attached to the chain.

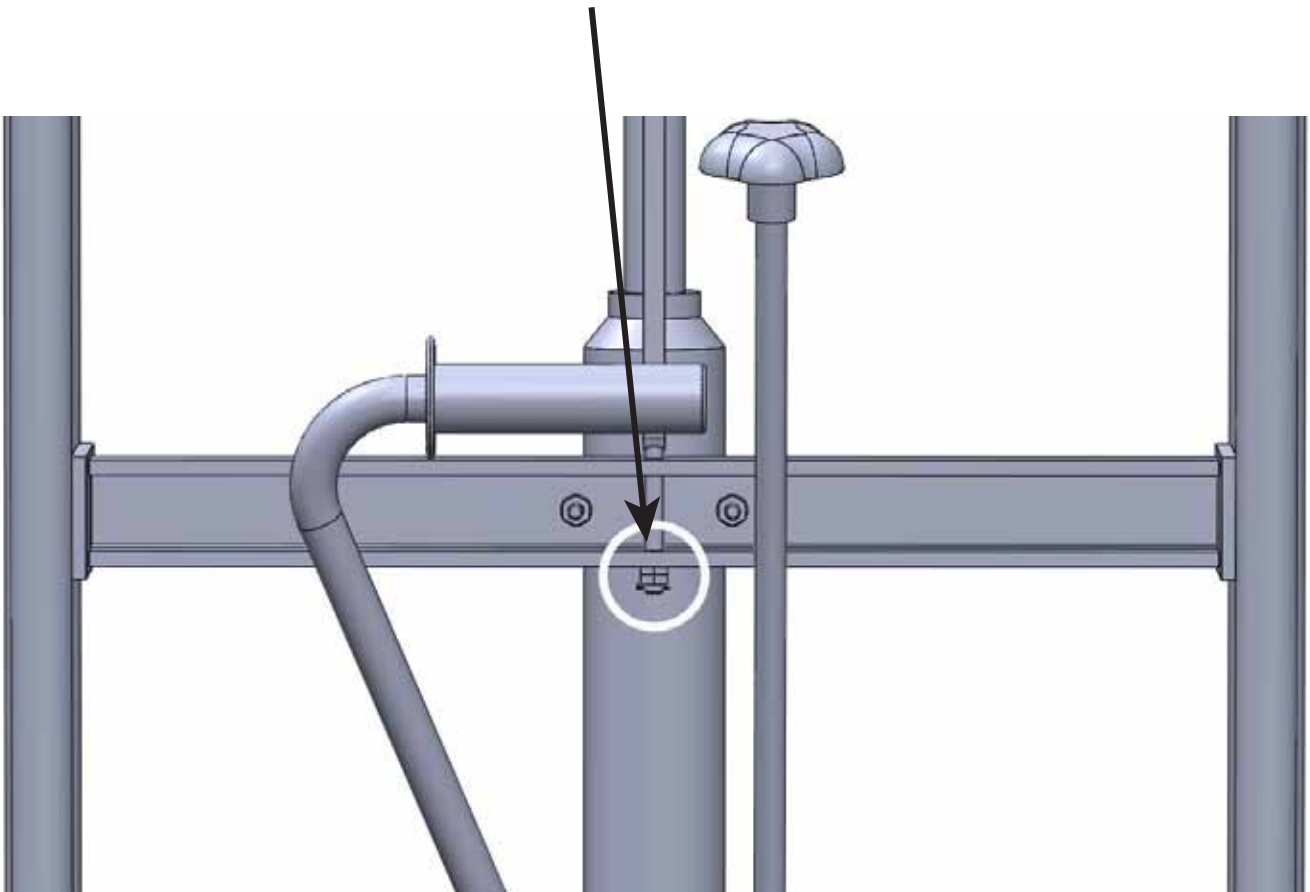

3. Oil Leaking

2. Remove 2 nuts from the U bolt.

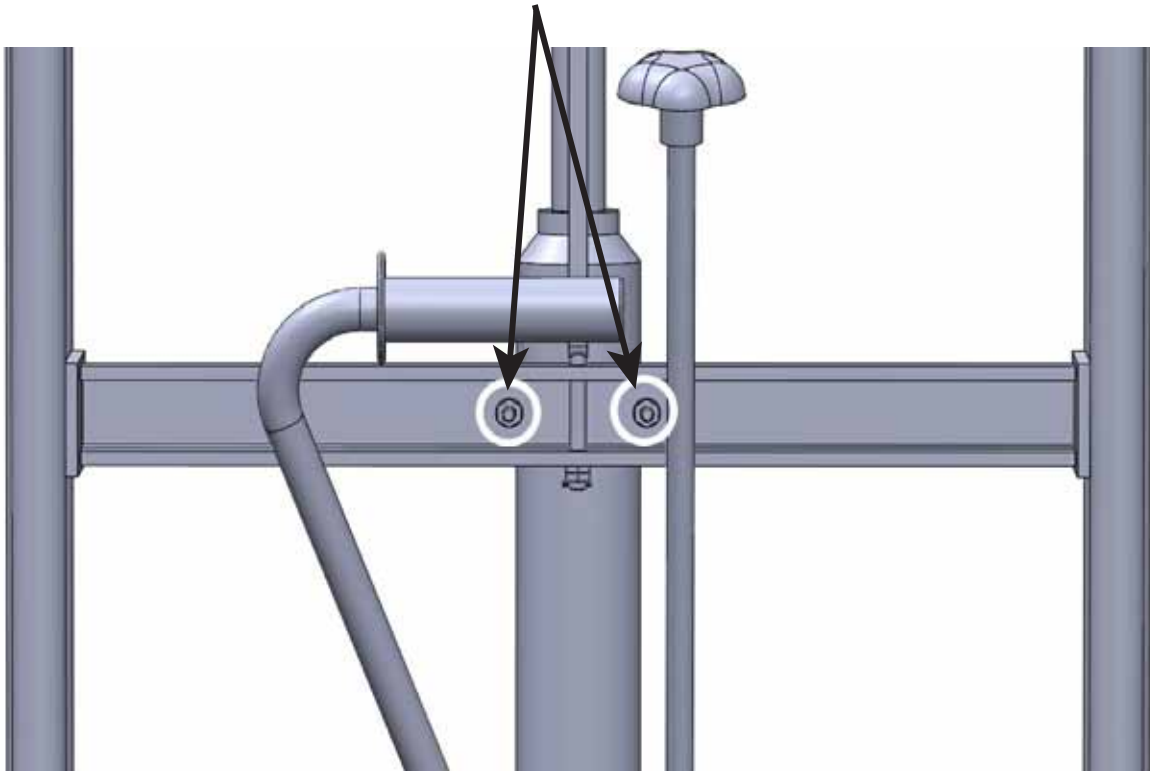

3. Lift the hydraulic pump.
 4. Pack it properly into thick packaging material to avoid the oil spilling.
 5. Replace with new hydraulic pump.
 6. Tighten 2 nuts from the U bolt and reattach the 2 nuts to the chain.

4. Roll Not Lifting

Check for leaking.

1. Open the oil filling screw:
2. Fill the pump unit with 10-20 ml hydraulic oil, type L-HM46 Hydraulic oil (equivalent to ISO VG46).
3. Wait for few minutes for the oil to reach the bottom of the pump unit. Try to lift.
4. If still not lifting, add additional oil in 2 more steps until the tray begins to lift.

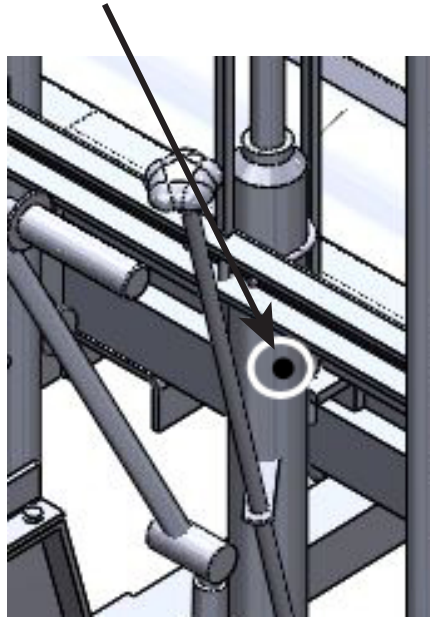

5. Tray Sinks Down Slowly

1. Replace the hydraulic pump as instructed in Instruction 3 "Oil Leaking".
2. Fill with more oil as instructed in Instruction 4 "Roll Not Lifting".
3. If still sinking, replace the seal of the lowering valve. See Instruction 6 "Oil Leaking at Release Valve".

6. Oil Leaking at Release Valve

1. Replace the hydraulic pump as instructed in step 3.
2. Open oil filling screw as instructed in step 4.
3. Turn the pump up-side down and empty oil into a bottle for later reuse.
4. Loosen screw (a), remove screw (b) and slide sprint sideward.
5. Loosen screw (c) and side it sideward. Remove the metal rod.

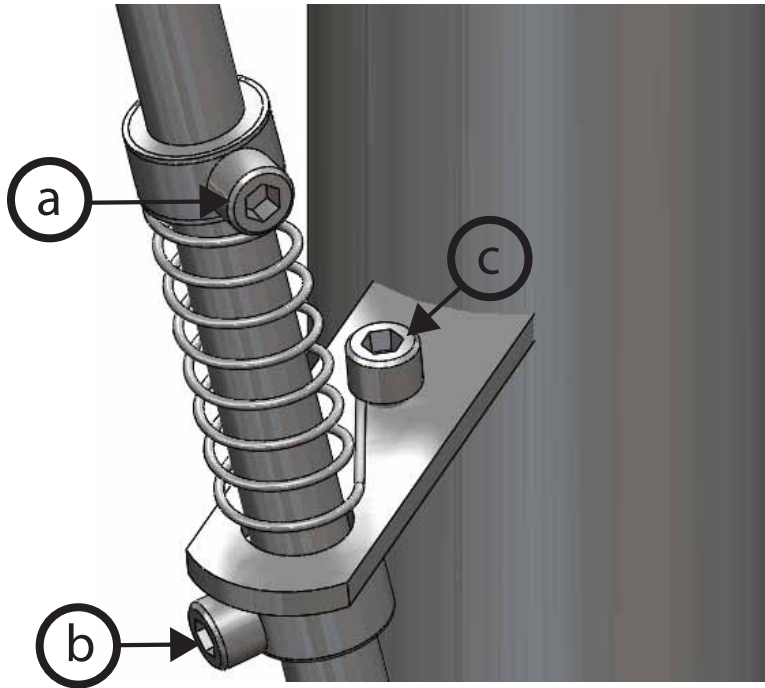

6. Unscrew the valve core and replace the 2 rubber rings.

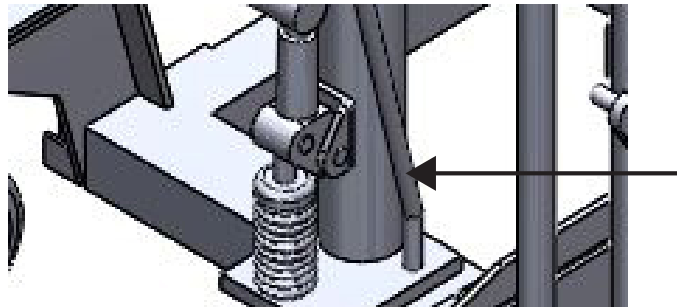

7. Reassemble the release valve.
8. Refill the oil into the pump.
9. Screw the oil filling screw.
10. Reassemble the hydraulic pump onto the lifter.

7. Oil Leaking at Other Points

1. Replace hydraulic pump.

8. Inspecting Hydraulic Cylinder for Leaks

1. Wipe clean any excess oil that has accumulated on the cylinder or carriage, with attention to the areas around the fill/drain plugs and pressure seals circled in the previous diagram. This will help identify any future leaks (if they occur). Also make sure the underside of the cylinder/carriage has been wiped clean, any residual oil may still drip.
2. Inspect the Drain plugs (a) and ensure they are tight. Do not over tighten.
3. Inspect the oil fill plug (b) and ensure it is tight. Do not over tighten.
4. If excessive fluid has been lost (tray does not raise) see Step 4 "Roll Not Lifting". Otherwise, continue to Instruction 6 "Oil Leaking at Release Valve":
 - a. Fill the pump unit with 10-20 ml hydraulic oil (Less is better), L-HM46 Hydraulic oil (equivalent to ISO VG46).
 - b. Wait for few minutes for the oil to reach the bottom of the pump unit. Try to lift.
 - c. If still not lifting, add additional oil in 2 more steps until the tray begins to lift.
5. Cycle the On-A-Roll Lifter® up and down several times (loaded) and observe the following areas for leaks:
 - a. Drain plug leaks (a) should be visible as the fluid drips below their respective ports.
 - b. Looking upward, the next potential leak area is the release valve (c). Leaking fluid will cascade down the valves pedestal, and down to other components.
 - c. The oil fill plug is next (b), and a leak would show a fairly visible streak of oil coming downward from the plug.
 - d. Lastly, if the hydraulic ram (d) is leaking, oil would appear above the oil fill plug and cascade downward. However, at this point, it is suspected that the lifter would not hold the media tray in place.
 - e. Consider the pump (e). A leak here is often difficult to find due to the spring obstructing the seal area, making pre-cleaning and inspection difficult..
6. If you should find any leak that was not corrected by tightening the fill/drain plugs, please contact Foster (1-800-523-4855) for advanced support.

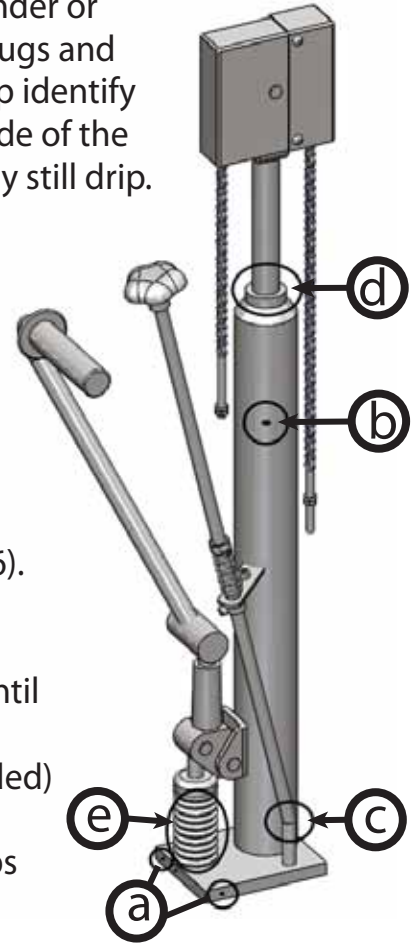

Note: If fluid has been added or the unit has been overfilled, it is possible that excess fluid may leak from the fill plug, when the lifter is in operation. The fill plug may continue to leak until the excess fluid is gone. This isn't a problem and the machine will still function normally.

9. On-A-Roll Lifter® Lift Pump Repair

1. Place protection material on the floor e.g. cardboard, to protect the floor from oil dropping.
2. Very carefully, lay the lifter in a horizontal position as shown:

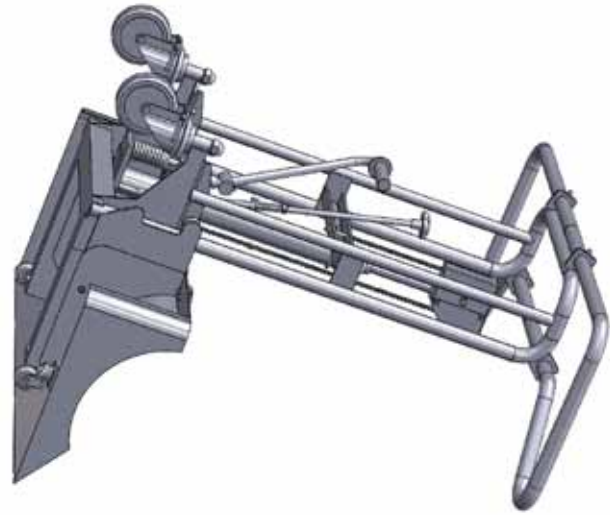

3. There are 6 points marked A, B, C, D, E in the next illustration. Identify the point of leakage and follow instructions.

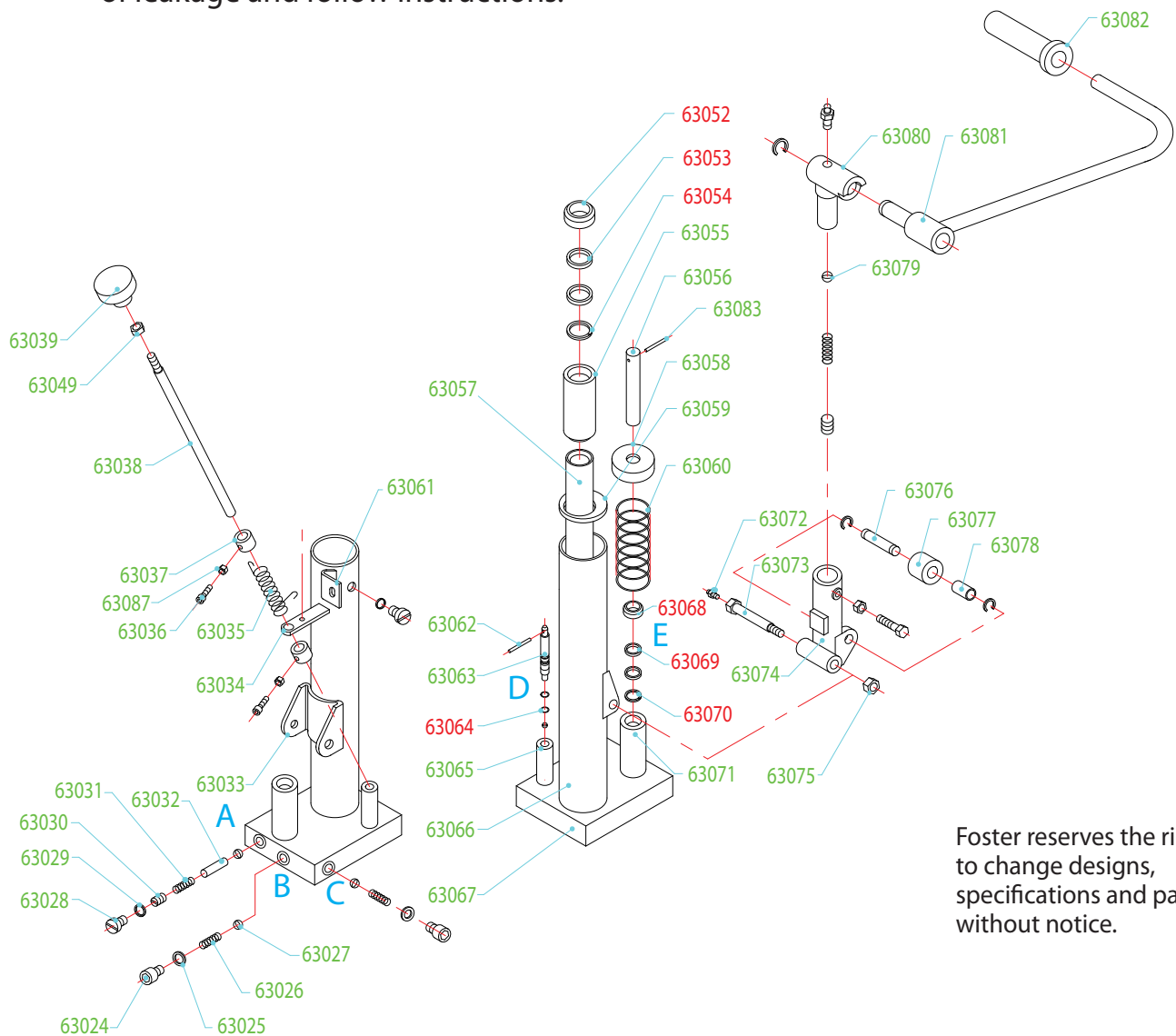

Foster reserves the right to change designs, specifications and parts without notice.

9. On-A-Roll Lifter® Lift Pump Repair

Point A

1. Unscrew the screw, part # 63028.
2. Remove the seal (63029), rubber screw (63030), coned spring (63031) and Pin (63032).
3. Inspect the parts if they are broken or worn out.
4. Replace the appropriate parts or all the parts and insert the parts as shown in the previous diagram.

Point B

1. Unscrew the screw, part # 63024.
2. Remove the seal (63025), coned spring (63026) and steel ball (63027).
3. Replace with all NEW parts and insert the parts as shown in the previous diagram.

Point C

1. Unscrew the screw, part # 63024.
2. Remove the seal (63025), coned spring (63026) and steel ball (63027).
3. Replace with all NEW parts and insert the parts as shown in the above diagram.

Point D

1. Make sure the On-A-Roll Lifter® is in the normal position.
2. Loosen screw (a), remove screw (b) and slide spring sideward.
3. Loosen screw (c) and slide it sideward.

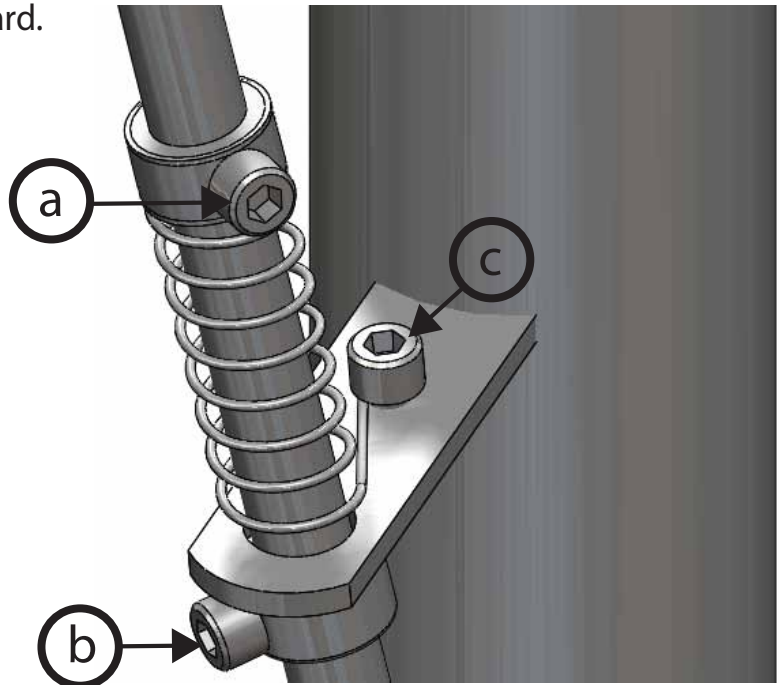

9. On-A-Roll Lifter® Lift Pump Repair

Point D

4. Remove metal rod.

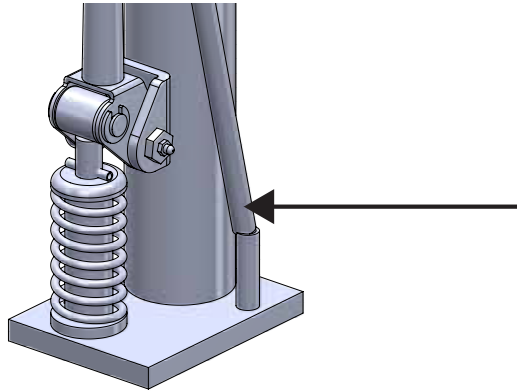

5. Unscrew valve core and replace the 2 rubber rings, Part 63064.

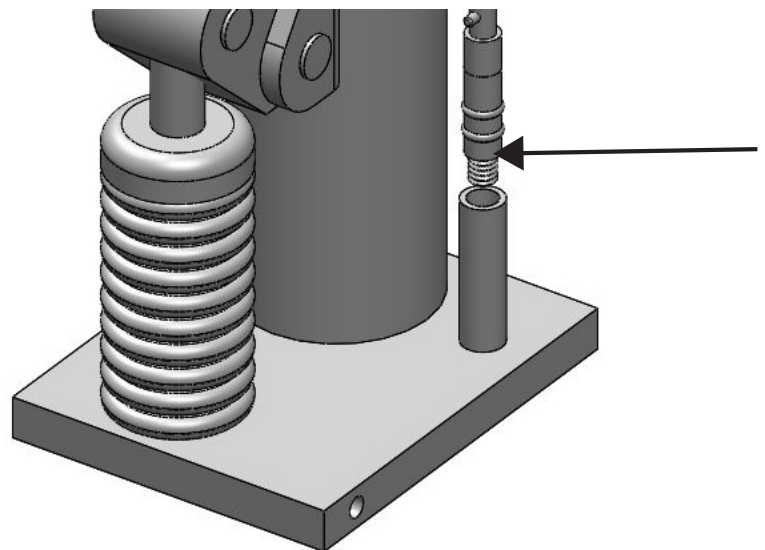

6. Reassemble the release valve.

Point E

1. Remove 1 of the retaining pins on the hydraulic pump foot pin.
2. Remove the hydraulic pump foot pin.
3. Remove the piston rod and inspect the parts if they are broken or worn out.
4. Replace the appropriate parts or all the parts and insert the parts as shown in the previous diagram.

