

# Foster

## NEW LIFTER OPTIONS

## ON-A-ROLL LIFTER® JUMBO

One operator can easily lift rolls as heavy as 990 lbs (450 kg), as wide as 16 feet 5 inches (500 cm), and with diameters as great as 19.6 inches. Designed in collaboration with EFI, Foster On-a-Roll Lifter® Jumbo is perfect for businesses operating grand- or extra-wide printers, fabric printers, or those handling floor coverings and similar materials.



# 63292  
Roll Ramp  
Tray



# 63215  
Roller  
Platform



## IMPORTANT FEATURES

- Pair of heavy-duty swivel casters with easy step-on locking brake
- Reduces on-the-job injuries and enables all workers to move heavy rolls
- User-friendly operation avoids costly and dangerous handling mistakes that damage media
- Rugged construction ensures long lifter life
- Single-person operation saves labor and time

## MODEL 61577

Roll Weight Capacity	450 kg (990 lbs)
Max. Lift Height	150 cm (58.95")
Max. Roll Width	500 cm (16'5")
Max. Roll Diameter	50 cm (19.6")
Width x Depth	120 cm x 77.48 cm (47.24" x 30.51")
Height	155.5 cm (61.22")
Weight	134 kg (295 lbs)
Bottom Fork Clearance	11 cm (4.33")
Front Swivel Castors	3" Ø x 1.81"W
Rear Swivel Castors	5" Ø x 1.46"W

2-year warranty on all wheels, hydraulics and media tray.  
5-year warranty on cross bars.

toll free (USA and Canada only) 800.523.4855 or 267.413.6220 • fax 267.413.6227

204B Progress Drive, Montgomeryville, PA 18936 USA • information@go-foster.com • www.go-foster.com



## ON-A-ROLL LIFTER® JUMBO SPECIFICATIONS 61577

Use the drawings below and the specifications overleaf to ensure the On-a-Roll Lifter Jumbo is right for your shop.

- THINGS TO CONSIDER:
- Maximum lift height required
  - Maximum and minimum roll diameter
  - Will any obstructions prohibit moving the lifter close to the receiving machine?

Still have questions? Call 800.523.4855

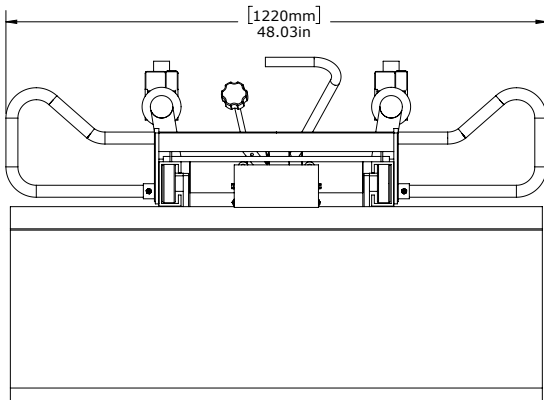

**Roll Tray** included for easy loading from pallets and handling large diameter, heavy rolls.



# 63292 **Roll Ramp Tray** for easy loading from the floor and handling large diameter, heavy rolls.



# 63215 **Roller Platform** is designed to allow operators to feed rolls into their machines directly from the lifter.

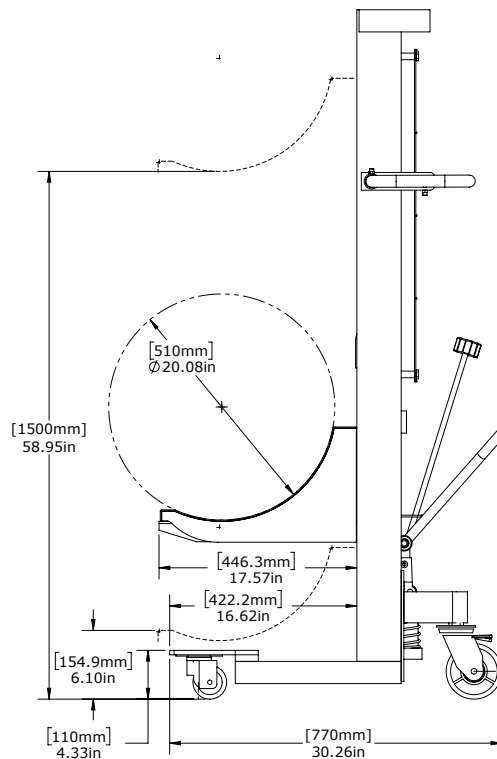
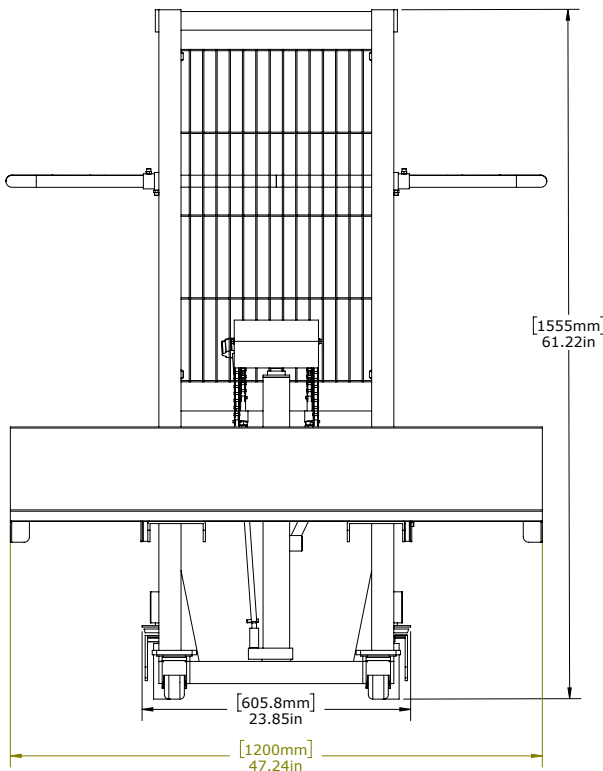

toll free (USA and Canada only) 800.523.4855 or 267.413.6220 • fax 267.413.6227

204B Progress Drive, Montgomeryville, PA 18936 USA • [information@go-foster.com](mailto:information@go-foster.com) • [www.go-foster.com](http://www.go-foster.com)