

Foster

NEW LIFTER OPTIONS



ON-A-ROLL LIFTER® HI-RISE

A rugged lifter designed specifically for fabric printers, sign makers, converters, grand- and wide-format printers, or any business with the need to lift heavy media or fabric rolls. Sturdy steel construction permits lifting rolls as heavy as 440 lbs (200 kg) nearly 6 ft (180 cm). Solves the problem of loading converting machines or printers with high inputs. Enables fabric printers to easily lift rolls on to tall production tables for spreading, sewing, or finishing.

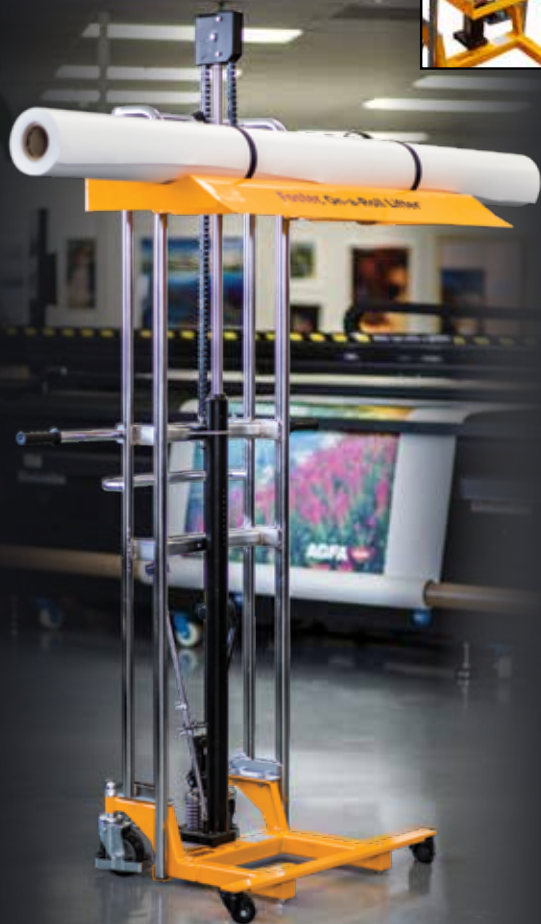

IMPORTANT FEATURES

- Reduces on-the-job injuries and enables all workers to move heavy rolls.
- User-friendly operation avoids costly and dangerous handling errors that damage media and potentially injure personnel.
- One-person operation saves time and labor.
- Rugged construction ensures long lifter life.
- Permits using higher than normal storage for media or fabric rolls.

MODEL 61570

Roll Weight Capacity.....	200 kg (440 lbs)
Lift Height	180 cm (71")
Max. Roll Width	180 cm (71")
Max. Roll Diameter	47 cm (18.5")
Width x Depth.....	120 cm x 80 cm (47.25" x 31.5")
Height.....	320.5 cm (80.7")
Weight	90 kg (198 lbs)
Bottom Fork Clearance	10 cm (4")
Front Swivel Castors.....	2.36" ø x 1.57"W
Rear Swivel Castors	5" ø x 1.46"W

2-year warranty on all wheels, hydraulics and media tray.
5-year warranty on cross bars.

toll free (USA and Canada only) 800.523.4855 or 267.413.6220 • fax 267.413.6227

204B Progress Drive, Montgomeryville, PA 18936 USA • information@go-foster.com • www.go-foster.com



ON-A-ROLL LIFTER® HI-RISE SPECIFICATIONS 61570

Is this On-a-Roll Lifter® the right fit for your printer?

Please use the dimensions below to help you determine if the On-a-Roll Lifter® Hi-Rise is the right fit for your printer. Still have questions? Call 800.523.4855.

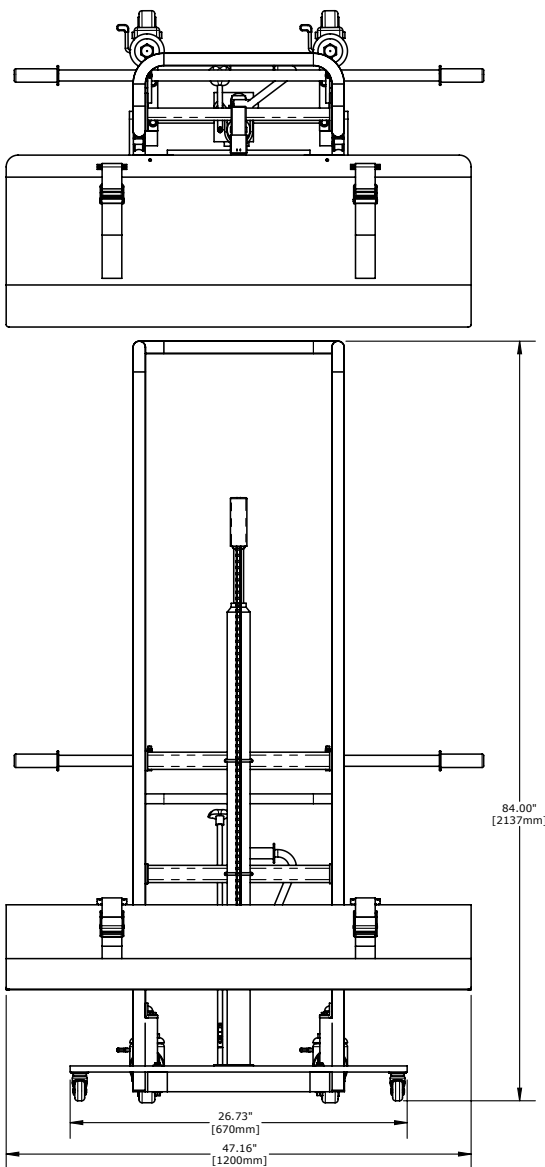

Roll Ramp Tray included for easy loading from the floor and handling wide rolls.



63161 **Roller Platform** is designed to allow operators to feed rolls into their machines directly from the lifter.

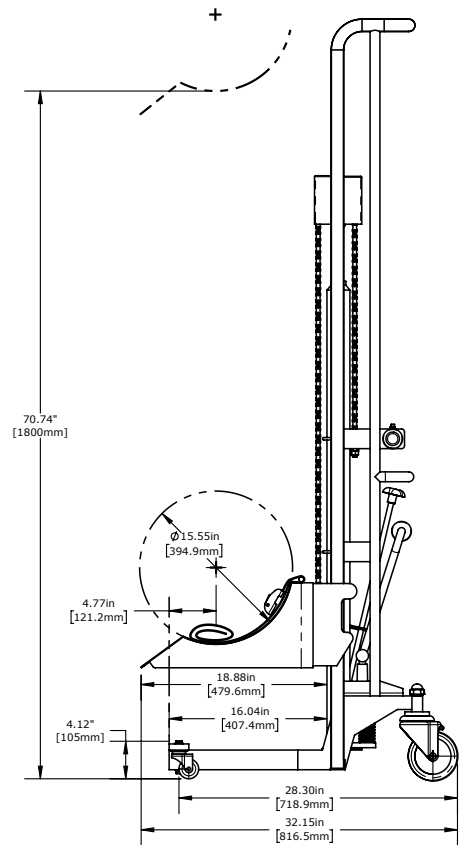

toll free (USA and Canada only) 800.523.4855 or 267.413.6220 • fax 267.413.6227

204B Progress Drive, Montgomeryville, PA 18936 USA • information@go-foster.com • www.go-foster.com